

USN

--	--	--	--	--	--	--	--	--	--

17AU82

Eighth Semester B.E. Degree Examination, Feb./Mar.2022
Mechanical Vibrations

Time: 3 hrs.

Max. Marks: 100

Note: Answer any FIVE full questions, choosing ONE full question from each module.

Module-1

- 1 a. Define : (i) Vibration (ii) Natural frequency (iii) Resonance (iv) Damping (v) Degrees of freedom (05 Marks)
b. Explain representation of harmonic motion in complex form. (05 Marks)
c. Add the following harmonic motions analytically and check the solution graphically:
 $x_1 = 4 \cos(\omega t + 10)$, $x_2 = 6 \sin(\omega t + 60)$ (10 Marks)

OR

- 2 a. Derive the equation of motion and natural frequency of vibration of spring mass system in vertical position using energy method. (10 Marks)
b. Determine the natural frequency of a spring mass system where the mass of the spring is also to be taken into account. Use energy method. (10 Marks)

Module-2

- 3 a. Set up the differential equation for a spring mass damper system and obtain the complete solution for critically damped system. (10 Marks)
b. Vibrating system consisting of mass of 50 kg, a spring of stiffness 30 KN/m and a damper. Damping is 20% of the critical value. Determine (i) Damping factor (ii) Critical damping coefficient (iii) Logarithmic Decrement (iv) Ratio of two consecutive amplitudes (v) Natural frequency of free vibration. (10 Marks)

OR

- 4 a. Define Whirling speed. Derive an expression for whirling of shaft without air damping. (10 Marks)
b. A steel shaft 25 mm diameter, 1.5 m long carries a disc of mass 5 kg at its centre and 2 kg at 0.5 m from one support. Find the whirling speed if $E = 2 \times 10^5 \text{ MN/m}^2$. (06 Marks)
c. Explain the following with equations,
(i) Logarithmic decrement
(ii) Damping factor (04 Marks)

Module-3

- 5 a. Define forced vibration with example. Derive an expression for motion of rotating unbalanced machine. (10 Marks)
b. A machine of total mass 68 kg mounted on springs of stiffness $K = 11,000 \text{ N/cm}$. Damping factor $\xi = 0.2$. A piston within the machine has a mass of 2 kg has a reciprocating motion with stroke 7.5 cm and a speed of 3000 rpm. Assuming the motion of piston to be S.H.M. Determine (i) Amplitude of machine (ii) Phase angle with respect to exciting force (iii) Transmissibility and force transmitted to foundation (iv) Phase angle of transmitted force with respect to exciting force. (10 Marks)

Important Note : 1. On completing your answers, compulsorily draw diagonal cross lines on the remaining blank pages.
2. Any revealing of identification, appeal to evaluator and /or equations written eg, 42+8 = 50, will be treated as malpractice.

OR

- 6 a. Explain Base Excitation. Derive an expression for absolute motion. (10 Marks)
 b. A mass of 100 kg been mounted on a spring dashpot system having spring stiffness of 19.600 N/m and damping coefficient of 100 N-sec/m. The mass is acted upon by a harmonic force of 39 N at the undamped natural frequency of system. Find (i) Amplitude of vibration of the mass (ii) Phase difference between force and displacement (iii) Force transmissibility ratio. (10 Marks)

Module-4

- 7 a. A two degree of freedom vibrating system is shown in Fig.Q7 (a). Determine the two natural frequencies of vibrations in a system. Given $m_1 = 2$ kg, $m_2 = 1$ kg, $K_1 = 40$ N/m, $K_2 = 20$ N/m. (10 Marks)

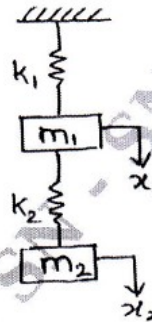

Fig. Q7 (a)

- b. A reciprocating machine of mass M runs at a constant speed of N rpm. After it was installed, it was found that the forcing frequency is too close to the natural frequency of the system. What dynamic vibration absorber should be added, if the nearest natural frequency of the system should be at least 25% from the impressed frequency? (10 Marks)

OR

- 8 a. With a block diagram, explain the basic vibration measurement scheme. (05 Marks)
 b. With a neat sketch and plot. Explain Vibrometer. (07 Marks)
 c. An accelerometer with a damped natural frequency of vibration of 160 Hz has a suspended mass of 0.02 kg when it is mounted on an engine, which is undergoing an acceleration of 10 m/sec^2 at operating speed of 6500 rpm. The acceleration recorded in the instrument is 9.75 m/sec^2 , determine damping constant and the spring stiffness of the accelerometer. (08 Marks)

Module-5

- 9 a. Derive the expression for natural frequency using Dunkerley's method. (08 Marks)
 b. Determine the influence coefficients of the triple pendulum shown in Fig. Q9 (b). (12 Marks)

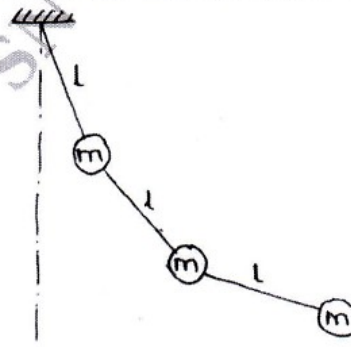

Fig. Q9 (b)

OR

- 10 a. Find the lowest natural frequency of vibration for the system shown in Fig. Q10 (a) by Rayleigh's method. $E = 1.96 \times 10^{11} \text{ N/m}^2$, $I = 4 \times 10^{-7} \text{ m}^4$ (10 Marks)

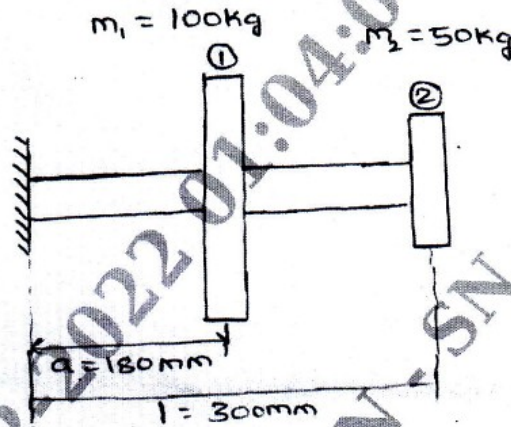

Fig. Q10 (a)

- b. Using Holzer method find the natural frequencies of the system shown in Fig. Q10 (b). Assume $m_1 = m_2 = m_3 = 1 \text{ kg}$, $K_1 = K_2 = K_3 = 1 \text{ N/m}$ (10 Marks)

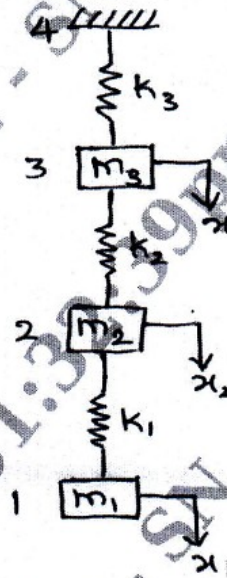

Fig. Q10 (b)
